

SEV50/SEVI50 高压直流接触器 HIGH VOLTAGE DC CONTACTOR

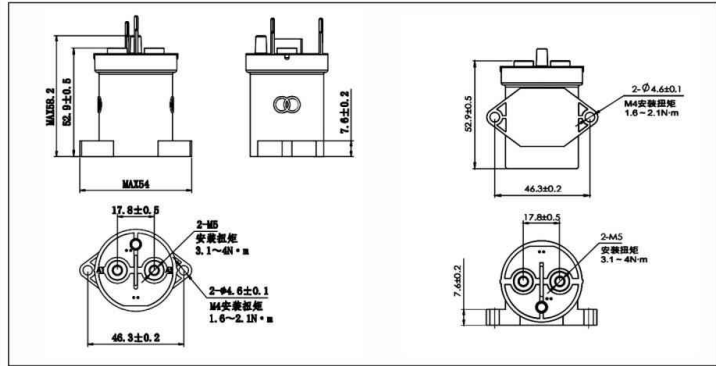

外形及安装尺寸 Outline and Dimensions:



产品特点 Product features:

- 全密封结构, 安全性高。
Full seal construction, high safety
- 线圈电压: 12、24 和 48 Vdc。
Coil voltage: 12、24、48 Vdc。
- 体积小, 切换功率大。
Small size, high switching power
- 采用环氧灌封密封技术对产品内部进行全密封, 保护线圈和触点系统长时间不氧化。
Full sealed inside by epoxy encapsulation technology to insure coil and contactor against being oxidized for long time
- 采用永磁体磁吹灭弧的技术, 产品可靠性高。
Use permanent magnet to eliminate electric arc, high reliability
- 执行标准: GB/T14048.5-2017
Implementation criteria: GB/T14048.5-2017
- 认证: CCC编号2017010303999702
Certification: CCC number 2017010303999702

型号解释 Type introduction:

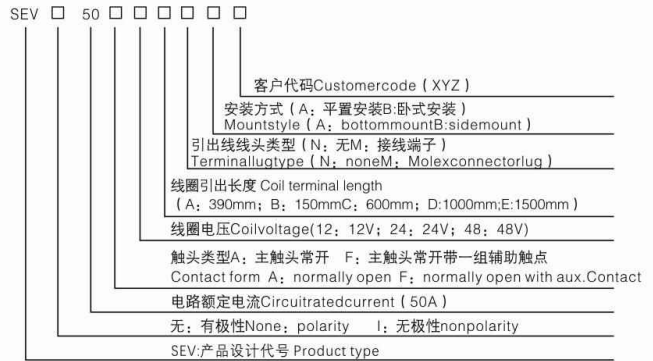

应用范围 Application:

新能源汽车的高压主回路、预充电回路、慢充电路、快充电路、高压辅助系统等; 充电桩的高压主回路系统; 风电, 光伏等电力控制系统。
Mainly used in high voltage main circuit, pre-charge circuit, slow charging circuit, fast charging circuit, high voltage auxiliary system of electromobile, as well as high voltage main circuit system in charging pile, power control system of wind power, photovoltaic.

线圈工作电压 Coil operating voltage:

序号 Item	工作电压 Nominal Voltage	12VDC	24VDC	48VDC
1	最大电压 Voltage (Max.)	16VDC	28VDC	52VDC
2	最大吸合电压 Pickup (close) Voltage (Max.)	9VDC	18VDC	36VDC
3	最小释放电压 Dropout (open) Voltage (Min.)	1.2VDC	2.4VDC	4.8VDC
4	线圈电流 Coil Current	461mA	250mA	122mA
5	线圈功耗 Coil Power (20°C)	5.5W	6.0W	6.0W
6	线圈电阻 Coil Resistance (20°C) ± 10% Ω	25	95	392

SEV50/SEVI50 高压直流接触器 HIGH VOLTAGE DC CONTACTOR



性能参数 Performance parameter:

类别	参数Parameters	单位Units	值Values
主触点 Main contactor	主触点, 触点形式 Contact Arrangement, Main Contacts	/	一组桥式常开(双动合触点)有极性、无极性两种可选 1 Form X(SPST NO DM)Polar, non - polar two options
	工作电压范围 Rated Operating Voltage	VDC	12-1000
	320VDC下断开电流 Break Current at 320VDC	A	750, 1次 (Cycle)
	标准接触电阻 (50A时) Standard contact resistance (@50A)	mΩ	≤0.5
	介质耐电压 Dielectric withstanding voltage	VAC	2500, (5mA, 60s)
	直流1000V下绝缘电阻 At DC 1000V insulation resistance	MΩ	≥100
辅助触点 Aux. contact	辅助触点、触点形式 Aux. contact, contact form	/	一组常开 1 Form A (SPST NO)
	辅助触点电流最大值 Aux. contact max current	A	30VDC 2A; 125VAC 3A
	辅助触点电流最小值 Aux. contact min current	mA	8V 100mA
	辅助触点接触电阻最大值 Aux. contact max contact resistance	Ω	30VDC 0.417; 125VAC 0.150
寿命 Life	负载寿命 Load life	50A/450V 50A/750V	cycle
	机械寿命 Mechanical life		cycle
吸合/释放 Operate/Release	吸合时间 (包括触点弹跳) Operate time (includes bounce)		ms
	释放时间 Release time		ms
环境 Environment	冲击, 11ms, 1/2正弦波, 峰值吸合 Shock, 11ms, 1/2 Sine, Peak, Pick up		G
	振动, 正弦波, 80-2000Hz, 峰值 Vibration, Sine, 80-2000Hz, Peak		G
	工作温度 Working tempt.		°C
	标准重量 Standard weight		g

产品通、断电寿命预估 Product life estimated (make/break):

1. 阻性负载下产品通、断电寿命预估次数曲线
Product life estimated (make/break) curve under resistive load

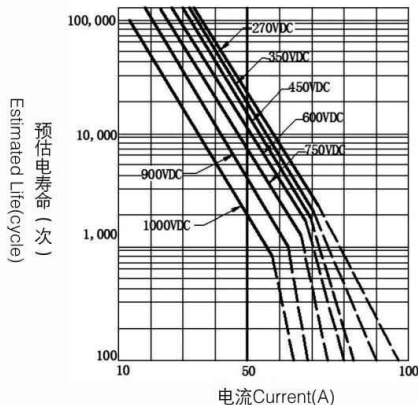

2. 持续通电能能力 Continuous current range

